

APPLICATION NOTE 105: Current Sense Circuit Collection

High Current (100mA to Amps)

Sensing high currents accurately requires excellent control of the sensing resistance, which is typically a very small value to minimize losses, and the dynamic range of the measurement circuitry

To see other chapters in this Application Note, return to the [Introduction](#).

Kelvin Input Connection Preserves Accuracy Despite Large Load Currents

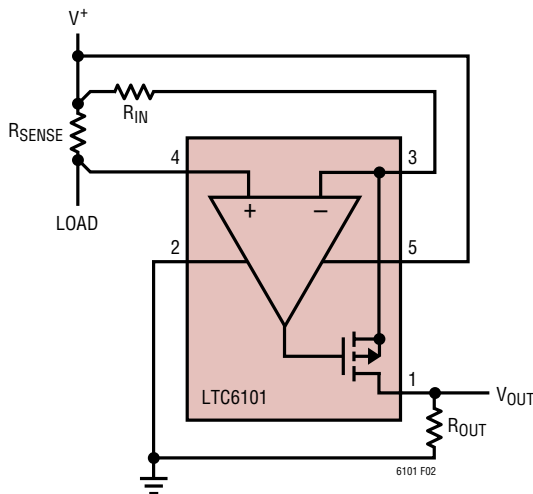

Kelvin connection of the IN- and IN+ inputs to the sense resistor should be used in all but the lowest power applications. Solder connections and PC board interconnections that carry high current can cause significant error in measurement due to their relatively large resistances. By isolating the sense traces from the high current paths, this error can be reduced by orders of magnitude. A sense resistor with integrated Kelvin sense terminals will give the best results.

Shunt Diode Limits Maximum Input Voltage to Allow Better Low Input Resolution Without Over-Ranging the LTC6101

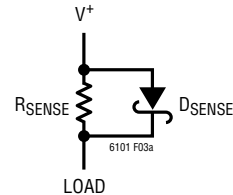

If low sense currents must be resolved accurately in a system that has very wide dynamic range, more gain can be taken in the sense amplifier by using a smaller value for resistor R_{IN} . This can result in an operating current greater than the max current spec allowed unless the max current is limited in another way, such as with a Schottky diode across R_{SENSE} . This will reduce the high current measurement accuracy by limiting the result, while increasing the low current measurement resolution. This approach can be helpful in cases where an occasional large burst of current may be ignored.

Kelvin Sensing

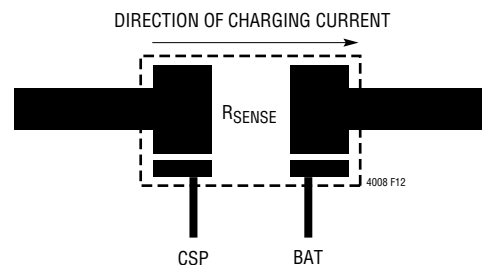

In any high current, >1Amp, application, Kelvin contacts to the sense resistor are important to maintain accuracy. This simple illustration from a battery charger application shows two voltage-sensing traces added to the pads of the current sense resistor. If the voltage is sensed with high impedance amplifier inputs, no $I \times R$ voltage drop errors are developed.

APPLICATION NOTE 105: Current Sense Circuit Collection

0A to 33A High Side Current Monitor with Filtering

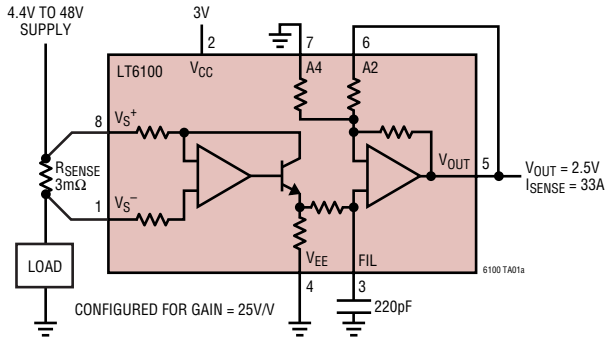

High current sensing on a high voltage supply rail is easily accomplished with the LT6100. The sense amplifier is biased from a low 3V supply and pin-strapped to a gain of 25V/V to output a 2.5V full scale reading of the current flow. A capacitor at the FIL pin to ground will filter out noise of the system (220pF produces a 12KHz low pass corner frequency).

Single Supply RMS Current Measurement

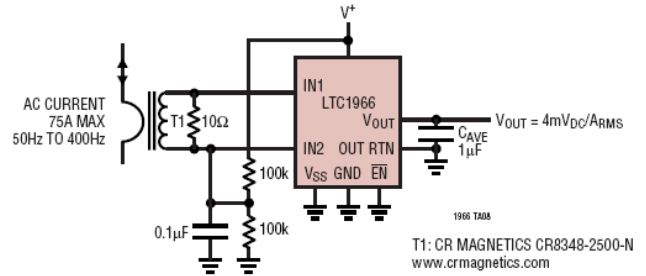

The LTC1966 is a true RMS-to-DC converter that takes a single-ended or differential input signal with rail-to-rail range. The output of a pcb mounted current sense transformer can be connected directly to the converter. Up to 75A of AC current is measurable without breaking the signal path from a power source to a load. The accurate operating range of the circuit is determined by the selection of the transformer termination resistor. All of the math is built in to the LTC1966 to provide a dc output voltage that is proportional to the true rms value of the current. This is valuable in determining the power/energy consumption of ac powered appliances.

Dual LTC6101's Allow High-Low Current Ranging

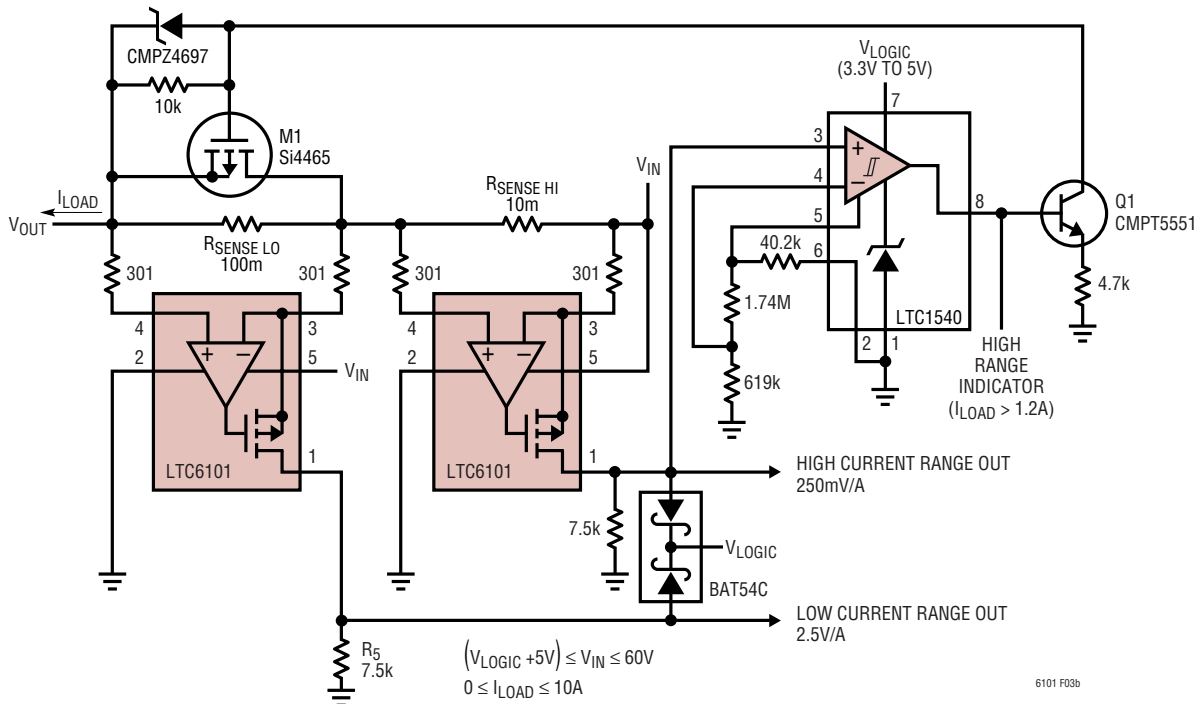

APPLICATION NOTE 105: Current Sense Circuit Collection

Using two current sense amplifiers with two values of sense resistors is an easy method of sensing current over a wide range. In this circuit the sensitivity and resolution of measurement is 10 times greater with low cur-

rents, less than 1.2 Amps, than with higher currents. A comparator detects higher current flow, up to 10 Amps, and switches sensing over to the high current circuitry.

LDO Load Balancing

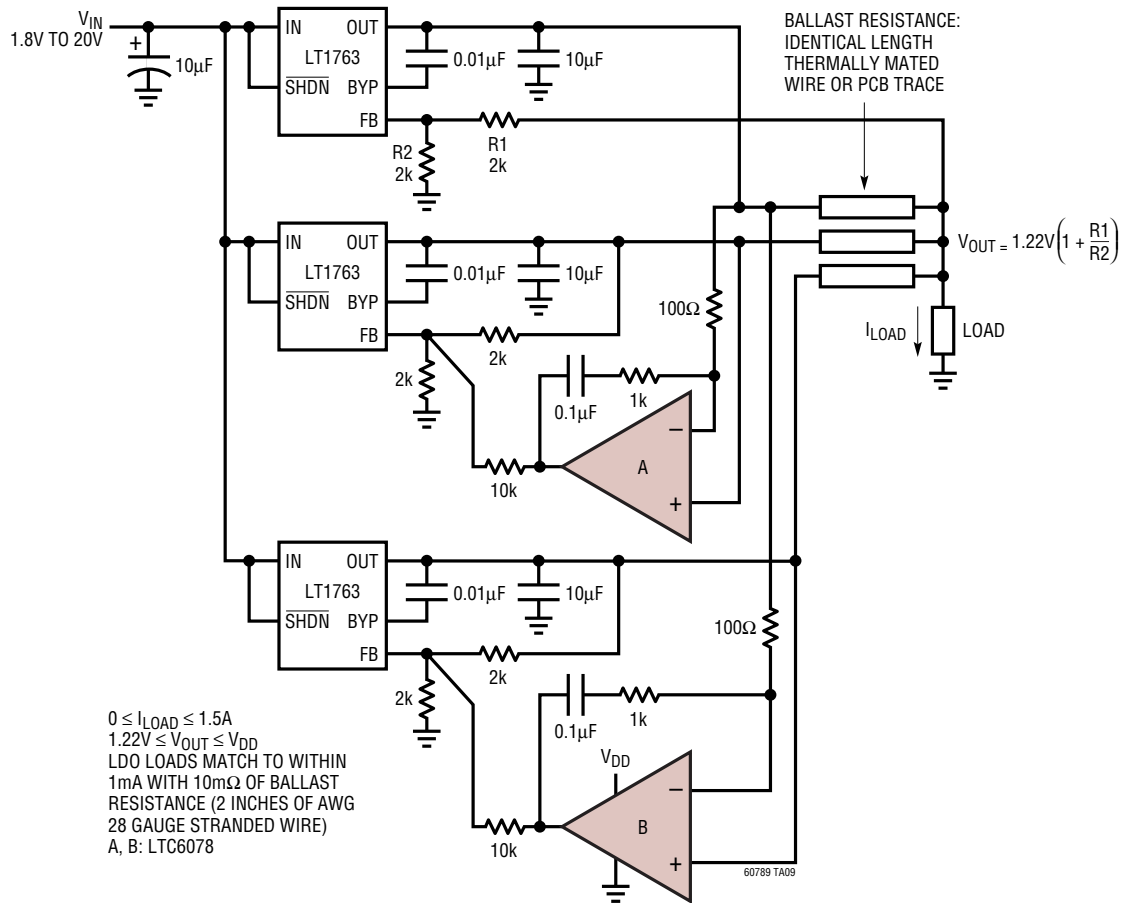

As system design enhancements are made there is often the need to supply more current to a load than originally expected. A simple way to modify power amplifiers or voltage regulators, as shown here, is to parallel devices. When paralleling devices it is desired that each device shares the total load current equally. In this circuit two adjustable “slave” regulator output voltages are sensed

and servo'd to match the master regulator output voltage. The precise low offset voltage of the LTC6078 dual op amp (10uV) balances the load current provided by each regulator to within 1mA. This is achieved using a very small 10mΩ current sense resistor in series with each output. This sense resistor can be implemented with pcb copper traces or thin gauge wire.

APPLICATION NOTE 105: Current Sense Circuit Collection

Sensing Output Current

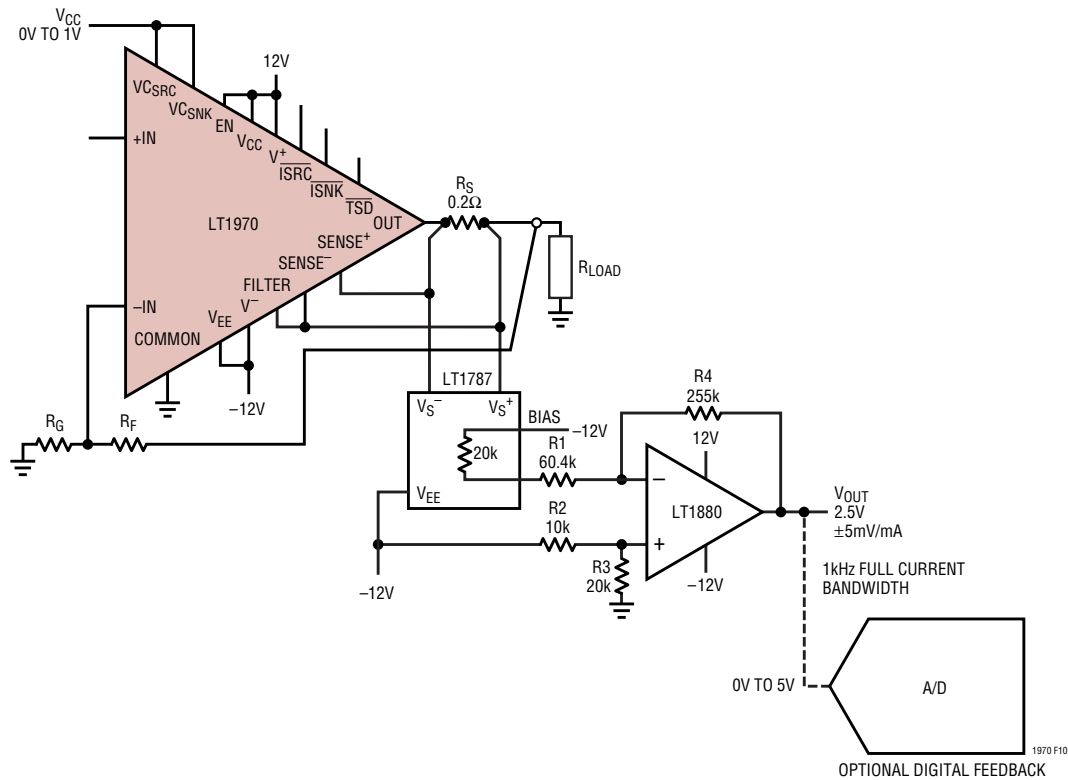

The LT1970 is a 500mA power amplifier with voltage programmable output current limit. Separate DC voltage inputs and an output current sensing resistor control the maximum sourcing and sinking current values. These control voltages could be provided by a D-to-A Converter

in a microprocessor controlled system. For closed loop control of the current to a load an LT1787 can monitor the output current. The LT1880 op amp provides scaling and level shifting of the voltage applied to an A-to-D Converter for a 5mV/mA feedback signal.